

Model	Capacity @ 500 mm LC	Power Type	Controller
2015A-T	1,500 kg	Electric	SME

2015A-T

Electric Three Wheel
Pneumatic Tire Forklifts



TOUGH WORLD. TOUGH EQUIPMENT.

2015A-T Electric • Three Wheel • Pneumatic Tire Forklift



General	1	Model			2015A-T
	2	Power Type			Electric
	3	Base Capacity	@ rated load center	kg	1,500
	4	Load Center		mm	500
Weights	5	Service Weight	unloaded with minimum weight battery	kg	3,050
	6	Axle Load	loaded, front / rear	kg	3,992 / 558
	7		unloaded, front / rear	kg	1,522 / 1,528
	8	Tire Type			Pneumatic
Tires	9	Wheels	front / rear		2 / 2
	10	Wheelbase		mm	1,340
	11	Tire Size	front		18 x 7 - 8
	12		rear		15 x 4.5 - 8
	13	Tread Width	front / rear		925 / 180
Mast	14	Max. Fork Height	with std 2 - stage mast	mm	3,000
	15	Freelift	with std 2 - stage mast	mm	135
	16	Height, Upright Lowered	with std 2 - stage mast	mm	2,045
	17	Height, Upright Extended	with std 2 - stage mast	mm	4,090
	18	Mast Tilt, Fwd / Back	with std 2 - stage mast	deg	6° / 7°
	19	Carriage	width	mm	1,040
	20	Fork Spread	minimum / maximum	mm	222 / 1,010
	21	Fork Dimensions	T x W x L	mm	35 x 100 x 920
Chassis	22	Length to Fork Face	with std 2 - stage mast	mm	1,935
	23	Overall Width		mm	1,110
	24	Overhead Guard Height		mm	2,025
	25	Turning Radius	minimum outside	mm	1,550
	26	Fork Overhang	with std 2 - stage mast	mm	385
	27	Right Angle Stack	add load length and clearance	mm	3,135
	28	Ground Clearance	minimum loaded	mm	60
	29		center of wheelbase	mm	105
	30	Battery Compartment	length / width / height	mm	565 / 830 / 675
	Performance	31	Travel Speed	loaded / unloaded	kph
32		Lift Speed	loaded / unloaded	m/s	0.35 / 0.5
33		Lower Speed	loaded / unloaded	m/s	0.5 / 0.4
34		Max. Drawbar Pull	5 min. rating	kg	1,275
35			60 min. rating	kg	316
36		Max. Gradeability	5 min. rating	%	20
Systems	37	Controllers	drive / hydraulic (make, type)		SME, AC
	38	Motors	drive output (60 min. rating)	kW	13
	39		hydraulic output (15 min. rating)	kW	15
	40	Battery	type		Lead Acid
	41		voltage		48
	42		max. capacity (6 hour rating)	Ah	480
	43		weight, minimum / maximum	kg	760 / 920

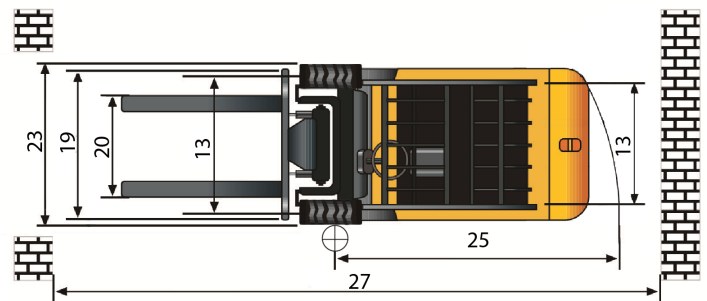
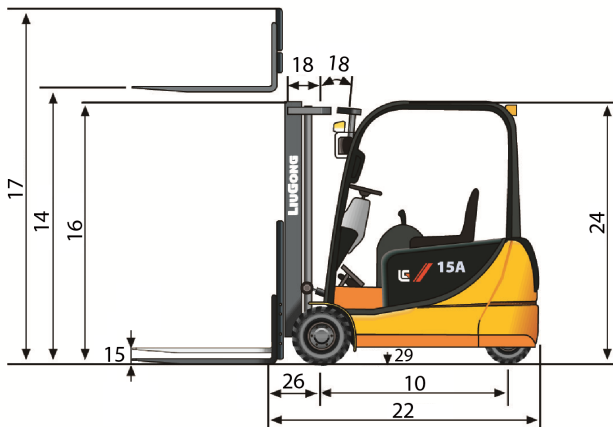

Guangxi Liugong Machinery Co., Ltd.
 No. 1 Liutai Road, Liuzhou, Guangxi 545007, PR China
 T: +86 772 3886124 E: overseas@liugong.com
 www.liugong.com

02/2014 Designed by LiuGong

Specifications and designs are subject to change without notice. Machines shown may include optional equipment.